

Model D-2 Yacht Horn

Kahlenberg Chimetone Air Horns all utilize more than one projector or “trumpet” in their design. These projectors each produce a different fundamental frequency which combine to produce powerful, distinctive, musical chords. To hear a Chimetone Air Horn is to realize that the sound of a vessel can be one of its most impressive aspects. The Model D-2 Air Horn is designed for the most discriminating yachtsman. It is made entirely of bronze and brass, and is triple plated for a deep chrome finish.



TECHNICAL DATA

Fundamental Frequency: 266 and 212 Hz
S.P.L. : (1/3 Octave @ 1 Meter): 132 dB

Air Consumption:

29 C.F.M. @ 100 p.s.i., 8 l/s @ 7 bar

Air Pressure Required:

100 to 250 p.s.i., 7 to 17 bar
(Higher pressures with optional regulators)

Electrical Power Required:

Any standard A.C. or D.C. Voltage

Material: Cast Bronze and Spun Brass

Net Weight: 33 lbs., 15 kg.,
D-2CVL: 44 lbs., 20 kg.

Finish:

White Powdercoat or Chrome Plate

Dimensions:

20.5" x 15.5" x 8.5" (524x394x217)

- **FOR VESSELS LESS THAN 75 METERS IN LENGTH**
- **MEETS OR EXCEEDS IMO REQUIREMENTS**
- **LOW AIR CONSUMPTION, OPERATES ON A WIDE RANGE OF AIR PRESSURE**
- **HIGHLY RELIABLE, VIRTUALLY NO MAINTENANCE**
- **OPTIONAL DIRECTLY MANIFOLDED MANUAL/SOLENOID VALVES, AIR STRAINER AND MANEUVERING LIGHT**

*Conforming to International Maritime Regulations
For Vessels Less Than 75 Meters in Length.*

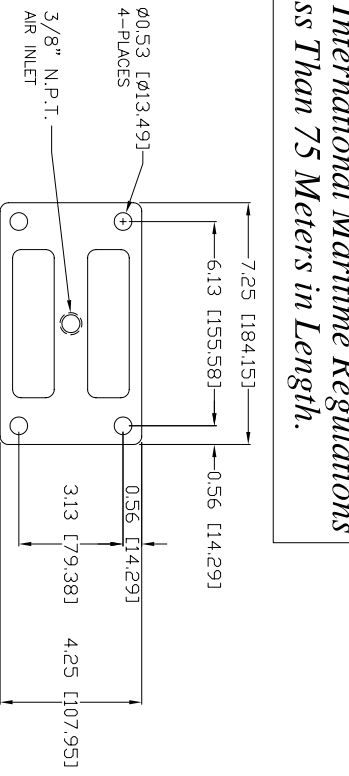

VIEW "A"- "A"

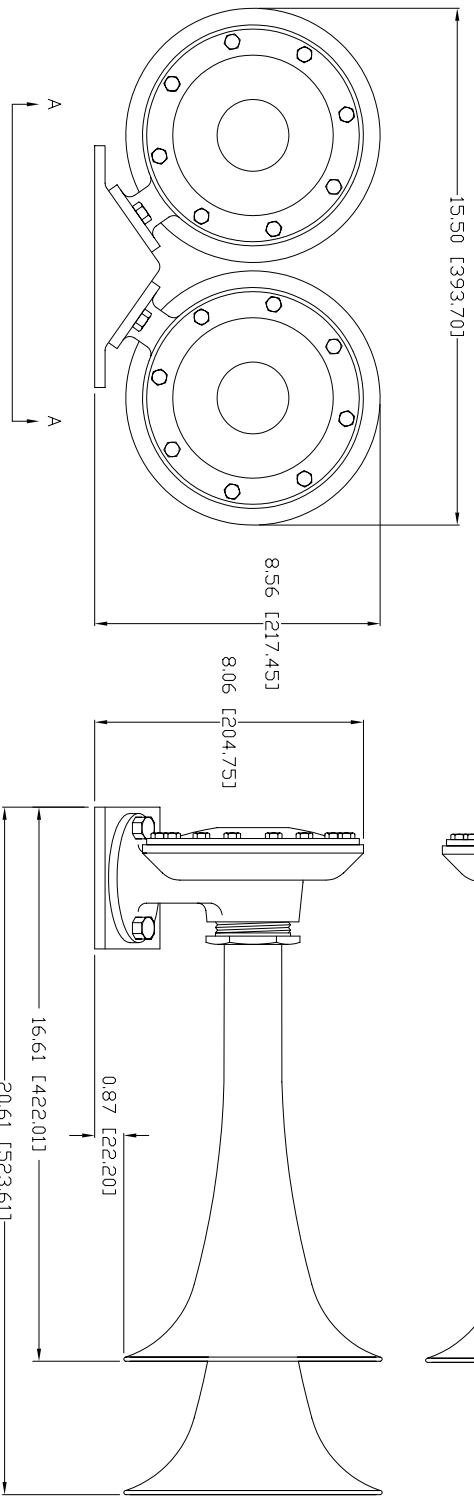

TECHNICAL DATA
 Frequency: 266 Hz & 212 Hz
 Sound Pressure Level (1/3 octave at 1 meter): 132dB
 Sound Pressure Level (dB(A) at 1 meter): 139dB
 Air Consumption: appx. 44 CFM @ 150 P.S.I.
 Air Pressure Req: 100 To 250 P.S.I.
 Electric Power: N/A
 Material: Spun Brass & Cast Bronze
 Net Weight: 33.00 Lbs.
 Shipping Weight: 40 Lbs.

Price: \$ _____ U.S.D. Net. Ea.
 (Valid for 60 days, F.O.B. Two Rivers, WI. U.S.A.)

REVISIONS

REV.	BY	DATE	DESCRIPTION	APP'D.
A	ZUN	10/16/08	S.P.L. 1/3 OCTAVE BAND WAS 139dB S.P.L. db(A) WAS 132dB	EMK



KAHLENBERG BROS. CO. TWO RIVERS, WI. U.S.A.

**MODEL D-2
AIRHORN**

DATE	DRWG. NO.	REV.
04/12/01	3-6089	A